

DR	REV	DATE	ECN NO	CHK BY	CHK ENG	APP ENG	ACC MFG
----	-----	------	--------	--------	---------	---------	---------

- NOTES:
- THIS UNIT IS CERTIFIED IN ACCORDANCE WITH ASME SECTION VIII, DIVISION 1.
 - THIS IS NOT A CERTIFIED "AS-BUILT" DRAWING. DO NOT USE DIMENSIONS FOR CONSTRUCTION.
 - FLANGE BOLT PATTERNS TO STRADDLE PRINCIPLE CENTERLINES.
 - NOZZLES ARE NOT DESIGNED WITH EXTERNAL PIPE LOADS CONSIDERED.
 - DIMENSIONS MARKED WITH AN ASTERISK (*) CARRY A $\pm 1/2$ " TOLERANCE DUE TO MATERIAL VARIANCES.
 - INSULATION: 2" THICK ARMAFLEX WITH ALUMINUM JACKET.
 - UNIT TO BE SHIPPED HORIZONTAL, SUPPORTED ON 12" NOZZLES.
 - BLIND FLANGE, BOLTING, AND GASKET TO BE SHIPPED LOOSE.

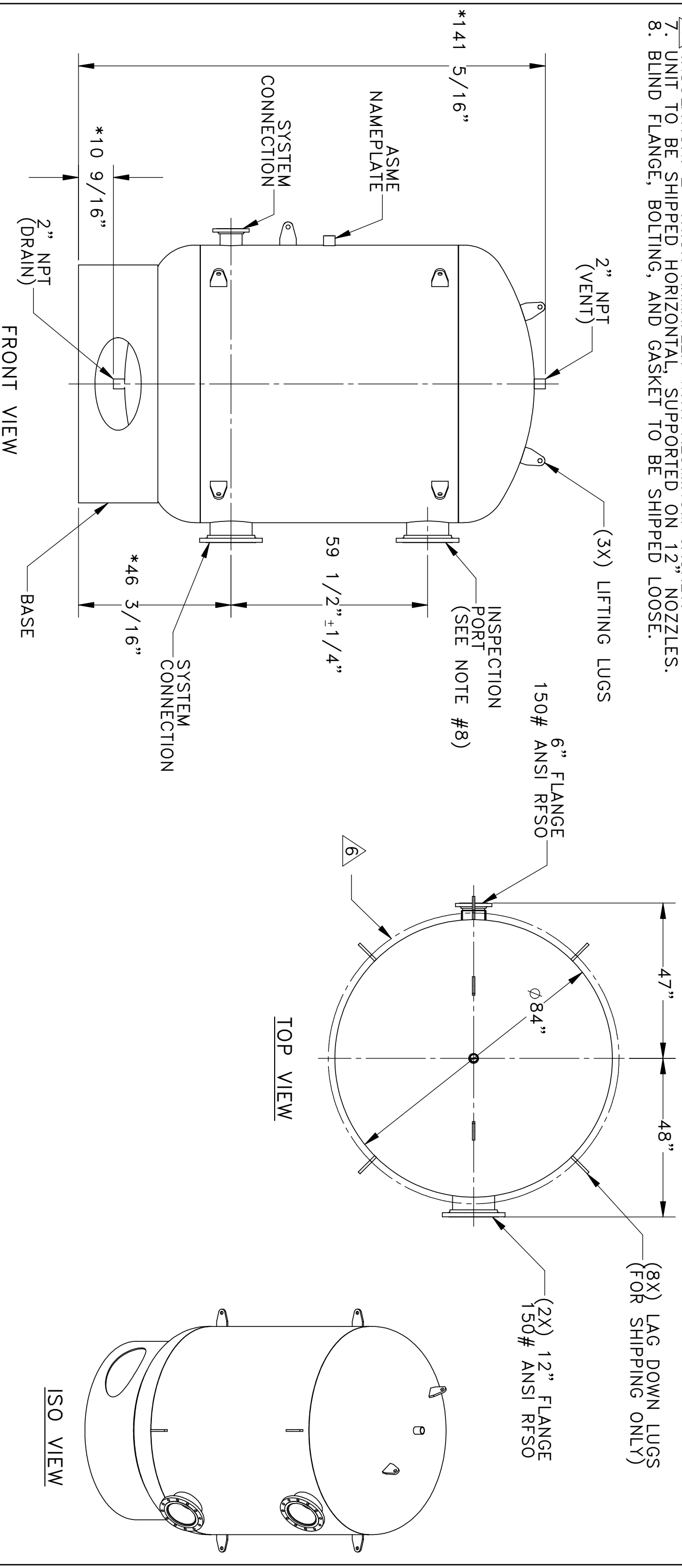

MODEL #:	CT2500F06 (SPECIAL)
REP.:	A WALDREP
SPA #:	1213-417A
P.O. #:	- - -
DESIGN CONDITIONS	
DESIGN PRESSURE	125 PSI
TEST PRESSURE	163 PSI
DESIGN TEMPERATURE	375.° F
MDMT	-20°F @ 125 PSI

UNLESS OTHERWISE SPECIFIED:	
FRACTIONS $\pm 1/4$	FINISHES 125° ✓
.XX $\pm .02$	RADII .005 TO .015
.XXX $\pm .005$	BREAK SHARP EDGES
.XXXX $\pm .0005$	
ANGLES $\pm 1^\circ$	
FEATURE CONTROL SYMBOLS PER ANSI Y14.5	

MAKE FROM:		CONSTRUCTION: CARBON STEEL	
EXT. FINISH: RED OXIDE PRIMER		INSULATION: SEE NOTE 6	
DR BY	EVG	CHK BY	-
DATE	12/31/13	SCALE	1:48
TRR/ECN	2252	WEIGHT	6750 LBS
		VOL	2500 GAL

Taco Inc. FALL RIVER, MA
CUSTOM VERTICAL TANK (INSULATED)

SIZE: **B** CT2500-M002

REV: -